

# **NorthStar**<sup>TM</sup> brand

## **Instruction Manual**

### **SLIM Tach<sup>®</sup> HS60 Magneto-resistive Encoder**

*Designed for use in*  
**1-1/8" to 2-7/8" (28.6mm-73.0mm)  
Hollow Shaft Applications**



**CE**  
EN 61326



**Customer Service:**  
Tel.: +1.800.873.8731  
Fax: +1.847.662.4150  
custserv@dynapar.com

**Technical Support**  
Tel.: +1.800.234.8731  
Fax: +1.847.782.5277  
northstar.techsupport@dynapar.com

**European Sales Representative**  
Hengstler GmbH  
Uhlandstrasse 49, 78554 Aldingen - Germany  
www.hengstler.de

**Website: [www.dynapar.com](http://www.dynapar.com)**

**\*702802-0001 Rev. A\***

# Table of Contents

Chapter/Paragraph/Illustration	Page
<b>1 Introduction.....</b>	<b>3</b>
1.0 Safety Summary.....	3
1.2 General.....	4
1.3 Description.....	4
<i>Figure 1: Customer Outline Reference Dimensions.....</i>	<i>4</i>
1.4 Specifications.....	5
<b>2 Installation.....</b>	<b>6</b>
2.0 Inspection and Unpacking.....	6
2.1 Mounting the HS60 to a C-Face Motor.....	6
<i>Figure 2: HS60 Anti Rotation Turnbuckle (Motor C-Face Mounting).....</i>	<i>6</i>
2.2 Mounting the HS60 to a Motor with a Fan Shroud.....	7
<i>Figure 3: HS60 Anti Rotation Turnbuckle (Fan Shroud Mounting).....</i>	<i>7</i>
<i>Figure 4: HS60 Anti Rotation Turnbuckle (Motor with Fan Shroud).....</i>	<i>7</i>
2.3 Electrical Installation.....	8
2.3.1 Quick Release Connector Hood Wiring.....	8
<i>Figure 5: Sealed Industrial Latching Connector.....</i>	<i>9</i>
2.4 Returning Equipment to Dynapar.....	9

Methods and apparatus disclosed and described herein have been developed solely on company funds of Dynapar No government or other contractual support or relationship whatsoever has existed which in any way affects or mitigates proprietary rights of Dynapar in these developments. Methods and apparatus disclosed herein may be subject to U.S. Patents existing or applied for. Dynapar reserves the right to add, improve, modify, or withdraw functions, design modifications, or products at any time without notice. Dynapar shall not be liable for errors contained herein or for incidental or consequential damages in connection with furnishing, performance, or use of this material.

## CHAPTER 1 INTRODUCTION

### 1.0 Safety Summary

High current, voltage, and rotating parts can cause serious or fatal injury. The use of electric machinery, like all other uses of concentrated power and rotating equipment, may be hazardous. Installing, operating, and maintaining electric machinery should be performed by qualified personnel, in accordance with applicable provisions of the National Electrical Code and sound local practices. Failure to comply with these precautions or with specific warnings elsewhere in this manual violates safety standards of design, manufacture, and intended use of the instrument. Dynapar assumes no liability for the customer's failure to comply with these requirements.

#### **Rotating Machinery**

Avoid contact with rotating parts. Avoid by-passing or rendering inoperative any safety guards or protection devices. Avoid extended exposure in close proximity to machinery with high noise levels. Use proper care and procedures in handling, lifting, installing, operating and maintaining the equipment.

#### **Before Installation**

Safe maintenance practices with qualified personnel is imperative. Before starting maintenance procedures, be positive that, (1) equipment connected to the shaft will not cause mechanical rotation, (2) main machine windings have been disconnected and secured from all electrical power sources, and (3) all accessory devices associates with the work area have been de-energized. If high potential insulation test is required, follow procedures and precautions outlined in NEMA standards MG-1.

#### **Grounding**

Improperly grounding the frame of the machine can cause serious or fatal injury to personnel. Grounding of the machine frame and structure should comply with the National Electrical Code and with sound local practices. Check wiring diagram before connecting power.

#### **Do Not Operate In An Explosive Atmosphere**

Do not operate the instrument in the presence of flammable gases or fumes. Operating any electrical instrument in such an environment constitutes a definite safety hazard.

#### **Keep Away From Live Circuits**

Operating personnel must not remove instrument covers. Component replacement and internal adjustments must be made by qualified maintenance personnel. Do not replace components with power cable connected. To avoid injuries, always disconnect power and discharge circuits before touching them.

#### **Do Not Substitute Parts Or Modify Instrument**

Do not install substitute parts or perform any unauthorized modification to the instrument. Introducing additional hazards is dangerous. Return the instrument to an authorized Dynapar representative for service and repair to ensure that safety features are maintained.

#### **Dangerous Procedure Cautions**

A CAUTION heading precedes potentially dangerous procedures throughout this manual. Instructions in the warnings *must* be followed.

## 1.2 General

These instructions do not claim to cover all details of variation in equipment or to provide for every possible contingency or hazard to be met in connection with installation, operation, and service. Should further information be desired or should particular problems arise which are not covered sufficiently for the purchaser's purposes, please contact Dynapar, or one of its designated representatives.

## 1.3 Description

The SLIM Tach<sup>®</sup> HS60 is a high performance, reliable digital tachometer, designed to provide position and velocity feedback from both AC and DC electric motors. The hollow shaft design allows ease of mounting on motors without accessory mounting flanges. Simply slide the HS60 onto the shaft, attach the anti-rotation arm to the motor, and tighten down the clamping collar that holds the unit onto the shaft. All of the critical alignments are already done for you in the encoder. The anti-rotation arm is very forgiving to any axial or radial motions that the motor might have, yet is very torsionally non-compliant.

Similar to NorthStar's heavy duty and mill duty encoders, the SLIM Tach<sup>®</sup> HS60 contains patented magneto-resistive technology. Magneto-resistive technology allows the NorthStar HS60 to be placed in the toughest environments. The unit is resistant to grease, oil, water, and dirt, making the HS60 the most rugged hollow shaft encoder on the market today. Operating voltages for the HS60 are 5-15 volts DC, and the electronics feature short circuit protection, reverse polarity protection, heavy duty line drivers, and EMI noise resistance. NorthStar provides a heavy duty, water-tight mating Industrial connector. The connector also features 1/2 inch NPT pipe thread for armored electrical conduit. The oversized, heavy duty bearings used in this unit are sealed and lubricated for life.

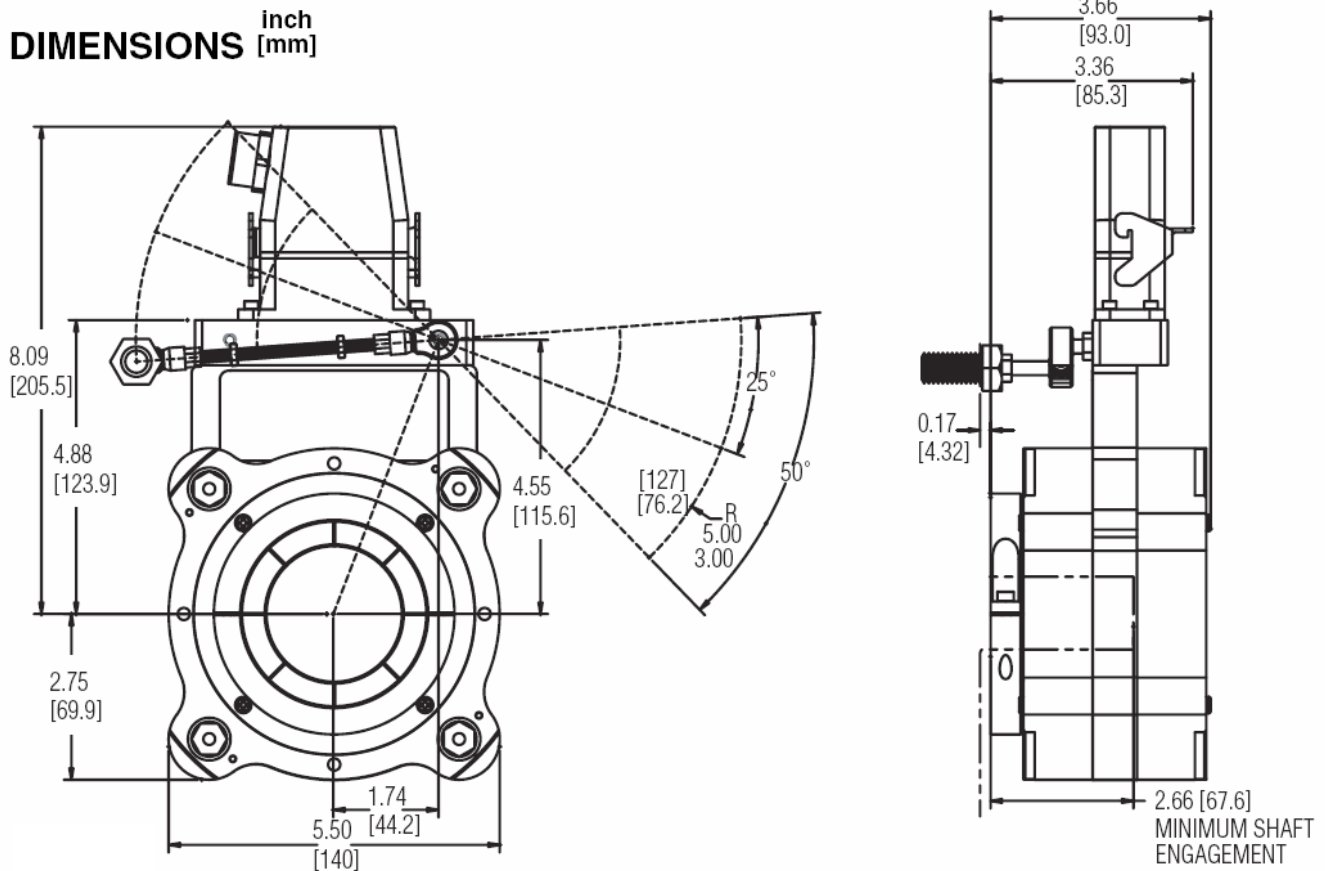

Figure 1: HS60 Customer Outline Reference Dimensions

1.3 Specifications

<b>Electrical Specifications</b>	
Resolution	512, 512Z, 1024, 1024Z, 2048 PPR
Frequency Response	0 – 120 KHz
Pulse Code	Incremental, Marker, Quadrature, Complements
Output Channels	A & B (incremental); Z (marker), A, B
Duty Cycle	50 ± 30% (within defined mechanical specs)
Quadrature Accuracy	A-B 90 ± 22°
Output Type	High Speed, Differential Driver
Rise and Fall Time	Less than 500ns @ 10,000 pf typical
Current Consumption	40 mA typical plus line driver load
ESD Protection	2kV
Output Current Capability	150 mA typical [350 mA maximum (worst case)]
Connector	10 pin Epic style, NEMA 4, 12 industrial connector
Suggested Cable	22 AWG, 8 Conductor, 18” length, 4 twisted shield pairs
Input Voltage	+ 5.0 to +15.0 VDC
<b>Mechanical Specifications</b>	
Maximum Operational Speed	3600RPM Labyrinth seal, 1000RPM V-seal
Shaft Requirements	1-1/8" to 2-7/8" diameter (+0.000, -0.0005) 2.66" minimum shaft length
Bearings	Sealed
Max Radial Runout	0.015” total indicated run out
Max Axial Travel	±0.150”
Box Weight	7 1/2lbs. (3.4 Kg)
Box Dimensions	8.75” x 14.25” x 4”
<b>Environmental Specifications</b>	
Operational Temperature	-20° to +80° C
Operational Humidity Capability	Maximum of 90%
Chemical Resistance	Salt spray, most solvents, mild acids and bases
Vibration	Maximum 15 g’s RMS, 5-2000 Hz
<b>Standards</b>	
*CE	EN 61326

**\*NOTE:** Provides CE compliance in applications where cable length is less than 30 meters.

Specifications subject to change without notice

## CHAPTER 2 INSTALLATION

### 2.0 Inspection and Unpacking

Inspect shipping container for external damage. All claims for damage (apparent or concealed) or partial loss of shipment must be made in writing to Dynapar within (5) days from receipt of goods. If damage or loss is apparent, please notify the shipping agent immediately.

Open shipping container and locate the packing list. The packing list is included to verify that all components, accessories, and manual were received. Please use the packing list to check off each item as the unit is unpacked. Inspect for damage. Dynapar recommends that the shipping container be retained for future shipping, storage, or return to factory purposes.

If any equipment was damaged in transit, be sure to file proper claims promptly with the carrier and insurance company. Please advise Dynapar of such filing. In case of parts shortages, advise Dynapar immediately. Dynapar cannot be responsible for any missing parts unless notified within 60 days of shipment.

### 2.1 Mounting the HS60 to a NEMA 180 or 56 C-Face Motor

1. When the HS60 is to be mounted onto a motor with opposite end NEMA C-Face, insert the appropriate bolt (i.e. 3/8"-16 UNC or 1/2"-13 UNC) (provided in hardware kit) into threaded hole on motor C-Face and tighten (see Figure 2). After positioning the encoder to the best angular orientation, adjust rod arm length (see Figure 2) and cut if necessary for proper fit. Align rod end turnbuckle assembly with bolt and tighten to 49 in-lbs. The HS60 anti-rotation arm assembly is designed to accommodate 4.5" and 8.5" C-Face mounting holes.
2. Slide the HS60 onto the motor shaft or stub shaft.
3. Attach the remaining end of the anti-rotation arm to the mounting bolt. Add a removable threaded locker and tighten the turnbuckle locking nuts.
4. Slide the clamping collar to the end of the encoder hubshaft closest to motor bearing. Tighten the clamping collar screws holding the encoder on the shaft with the hex wrench provided.

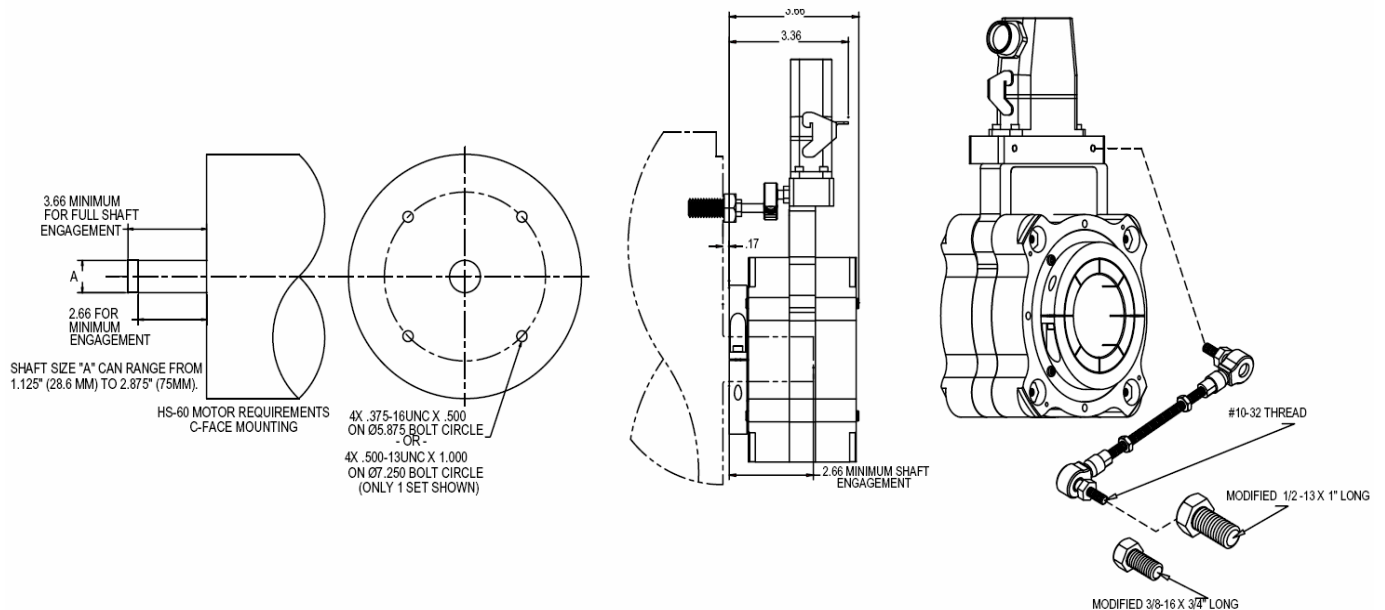

**Figure 2: HS60 Anti Rotation Turnbuckle (Motor C-Face Mounting)**

## 2.2 Mounting the HS60 to a Motor with a Fan Shroud

If the motor has only a fan shroud on the opposite drive end of the motor, use the mounting bolts on the end of the anti-rotation arm to mount the HS60 to the fan shroud. Figure 3 shows the anti-rotation arm attached to the fan shroud.

1. Arrange the anchor T-bolt as shown in Figure 4. Slide the anchor bolt into the fan shroud through an available vent.
2. Rotate the T-bolt 90° so the bolt catches the inside of the fan shroud.
3. With the anchor T-bolt positioned in the fan shroud, place ¼" washer over the bolt, tighten the hex standoff.
4. Insert anti-rotation rod end into the Hex standoff and tighten.

### **CAUTION!**

*The anchor bolt is designed for minimum ¼ inch of clearance between the fan and the fan shroud. If there is not ¼ clearance the fan may hit the anchor bolt head on the inside of the fan shroud. See drawing below. The minimum shaft length for fan shroud mounting is 2.65".*

5. Slide the HS60 onto the accessory shaft.
6. Slide the clamping collar to the end of the encoder hubshaft closest to motor bearing. Tighten the clamping collar screws holding the encoder on the shaft with the hex wrench provided. The anti-rotation arm should be parallel with the encoder and perpendicular to the shaft.

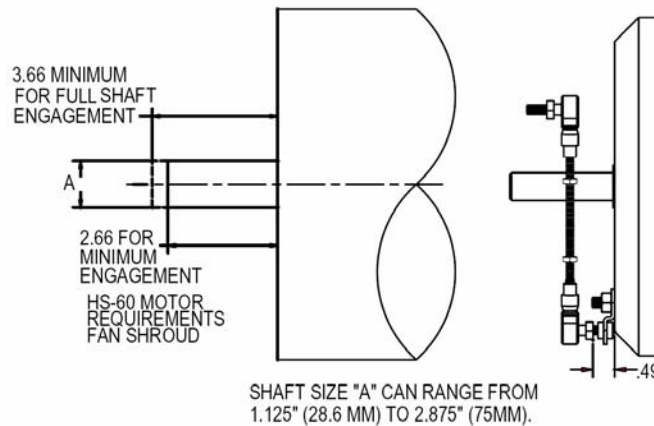

**Figure 3: HS60 Anti Rotation Turnbuckle (Fan Shroud Mounting)**

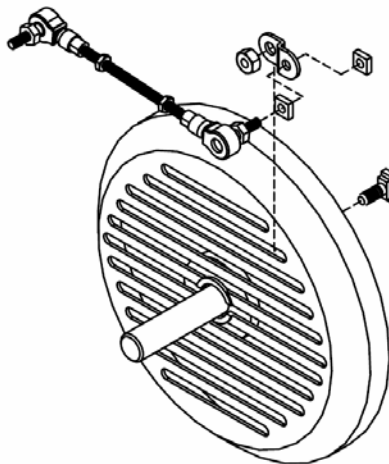

**Figure 4: HS60 Anti Rotation Turnbuckle (Motor with Fan Shroud)**

### 2.3 Electrical Installation

Electrical connections are made to the sensor module through a standard 1/2 inch NPT liquid tight flexible conduit. The nipple length may be changed to extend the outlet box if desired. Interconnection cable recommendations are as follows: stranded copper, 22 through 16 gage, braided or foil with drain wire shielding 0.05 μF maximum total mutual or direct capacitance, outer sheath insulated. Shrink tubing may be placed over any wires without insulation. For lengths over 100 feet, use 18 gage or larger, to a maximum of 1000 feet. If shielded twisted pair wire is used, do not cross channels. Keep each pair of complementary channel outputs together in a single twisted pair (e.g., A and A complement).

**\*NOTE:** Provides CE compliance in applications where cable length is less than 30 meters.

**Grounding:** For applications with high ground potential differences, DO NOT ground the encoder through both machine and controls end. Connect the shield at the controls end only. **NOTE: If the shield is connected at both ends, grounding problems that degrade system performance can result.**

**CE Grounding Measures** – For best EMC immunity the cable screen must be grounded on both encoder and controls end. For cable lengths longer than 30m or outdoor applications, additional measures must be implemented to comply with CE requirements. Connection of the encoder to DC power supply network is prohibited if CE compliance is required. CE-compliant products are tested to EN61326-1 EMC.

In all cases, system CE compliance is ultimately the responsibility of the manufacturer integrating the encoder.

### **CAUTION!**

*Reversing power and common will not damage the unit. However, applying power to any of the sensor outputs may cause damage.*

Table 1. Signal Coding Table

Signal	Connector Pin	Pigtail Cable	MS 3102E18-IT#
Common	1	Black	F
B	2	Green	B
A	3	Blue	A
Z *	4	Violet	C
No Connection	5	----	E
Vcc (5-15 VDC)	6	Red	D
/B	7	Yellow	I
/A	8	Gray	H
/Z *	9	Orange	J
Shield	10	Braid	G

\* Applies only to units with index pulse capability.

# Pinouts are for the sensors with the MS 3102E18IT connector

### **NOTE**

*The shield in the sensor module is isolated from the frame of the encoder. For maximum noise immunity, the shield wire or pin should be connected to the shield of the cable and that of the drive or other receiving device.*



### 2.3.1 Quick Release Connector Hood Wiring

To install the Quick Release Connector, perform the following steps.

1. Remove the four screws from the mating connector housing that hold the terminal block in place. Remove terminal block from housing.
2. Insert wiring through liquid tight flexible seal and mating connector housing. Leave enough wire exposed to comfortably reach the terminal block. Wire to terminal block according to wire code in Table 1. A similar wiring list is attached to enclosure.

#### **NOTE**

*There are two orientations of the connector hood. The terminal block can be inserted either way so the connector hood points up or down. Choose the direction best for your application.*

4. Tighten Liquid Tight fitting on housing. **OPTIONAL:** In some hostile environments, seal between connector body and Sensor Module can be improved by smearing a sealant (silicone grease, etc.) on the neoprene seal of the connector.
5. Mate connector into place on sensor mount and snap the two latches into place. If only one sensor is being installed, ensure cover plate is installed over other sensor hole.

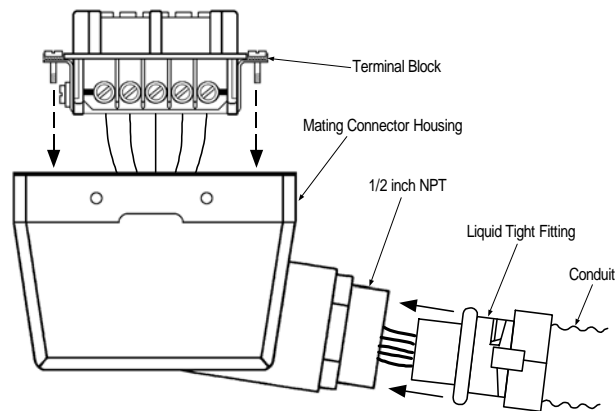

**Figure 5: Sealed Industrial Latching Connector**

### 2.4 Returning Equipment to Dynapar

If it is necessary to return the unit for repair or replacement, a Return Goods Authorization (RGA) number must be obtained from a factory representative before returning the equipment to our service department. When returning an instrument for service, the following information must be provided before we can attempt any repair.

1. Instrument model and serial number
2. User's name, company, address, and phone number
3. Malfunction symptoms
4. Description of system
5. Returned Goods Authorization number

Consult the factory for shipping instructions.



**Customer Service:**

Tel.: +1.800.873.8731  
Fax: +1.847.662.4150  
custserv@dynapar.com

**Technical Support**

Tel.: +1.800.234.8731  
Fax: +1.847.782.5277  
northstar.techsupport@dynapar.com

**European Sales Representative**

Hengstler GmbH  
Uhlandstrasse 49, 78554 Aldingen - Germany  
www.hengstler.de

**Website: [www.dynapar.com](http://www.dynapar.com)**